

# Conmutadores de transferencia MTSE

4 POLOS / 40 - 125 A

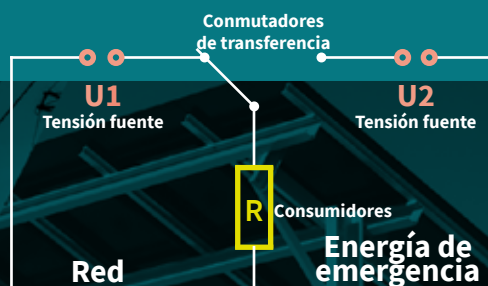

**60947-6-1**



*cumple la norma internacional IEC 60947-6-1*



*Switch to Quality!*

# ESPECIFICACIONES TÉCNICAS

<b>Conmutador MTSE</b>			040 4VU3B	040 4VU	063 4VU3B	063 4VU	125 4VU3B	125 4VU
Punto de unión Módulo N			no	yes	no	yes	no	yes
Voltaje de operación $U_e$	VAC		690	690	690	690	690	690
Tensión impulso $U_{imp}$	kV		6	6	6	6	8	8
Corriente ininterrumpida $I_u/I_{th}/I_{the}$	A		40	40	63	63	125	125
Calibre máximo fusible	gL		40	40	63	63	125	125
Corriente condicional de cortocircuito	kAeff		15	15	-	-	25	25
Capacidad de cierre en cortocircuito	kA		-	-	1,8	1,8	-	-
Características de aislamiento según EN 60947, hasta	VAC		690	690	690	690	1000	1000
Angulo de conmutación			90°	90°	90°	90°	90°	90°
Contactos	max		8	8	8	8	8	8
Capacidad terminales								
- Rígido o	min	mm <sup>2</sup>	1	1	6	6	4	4
- Trenzado	max	mm <sup>2</sup>	10	10	25	25	50	50
- Flexible o multifilar	min	mm <sup>2</sup>	0,75	0,75	4	4	2,5	2,5
- Incluyendo puntera	max	mm <sup>2</sup>	6	6	16	16	35	35
Calibre Cables Americano	AWG		8	8	4	4	1/0	1/0
Corriente de operación $I_e$								
- AC-21A	A		40	40	63	63	125	125
- cUL	300V AC	A	40	40	63	63	100	100
- Uso General	600V AC	A	40	40	63	63	100	100
Potencia de operación a 50-60Hz (3 fases)								
AC-23A	220-240V	kW	7,5	7,5	15	15	30	30
	380-440V	kW	15	15	22	22	45	45
	500V	kW	15	15	22	22	45	45
	660-690V	kW	15	15	22	22	37	37
AC-3	220-240V	kW	5,5	5,5	11	11	30	30
	380-440V	kW	11	11	18,5	18,5	37	37
	500V	kW	11	11	18,5	18,5	45	45
	660-690V	kW	11	11	18,5	18,5	37	37
cUL	110-120V AC	HP	3	3	5	5	15	15
	208V AC	HP	7,5	7,5	-	-	-	-
	220-240V AC	HP	7,5	7,5	10	10	30	30
	440-480V AC	HP	15	15	20	20	60	60
	550-600V AC	HP	15	15	20	20	50	50

## Montaje:

Carril DIN estándar de 35 mm con placa frontal de 45 mm para cuadros de distribución, Mando negro y placa frontal en color plata

Vida útil mecánica:  $>10^5$  ciclos de operación

Resistencia climática: Calor y humedad, constante, según DIN IEC 60068-2-78 / ciclo de calor y humedad según DIN IEC 60068-2-30

Temperatura ambiente: abierto: -25/+50 °C. (min/max) / encapsulado: -25/+40 °C. (min/max)

Capacidad de carga en operaciones intermitentes, Clase 12 AB: 60%/40%/25% DF:  $1.3/1.6/2 \times I_e$

Estándar IEC 60947-6-1, EN 60947-6-1, IEC 60204, EN 60204, ANSI/UL 60947-1, ANSI/UL 60947-4-1A

# ESQUEMA DE CONTACTOS

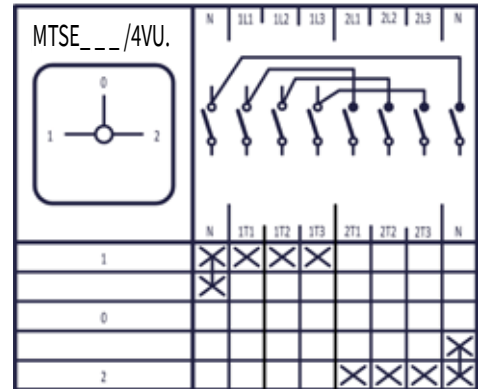
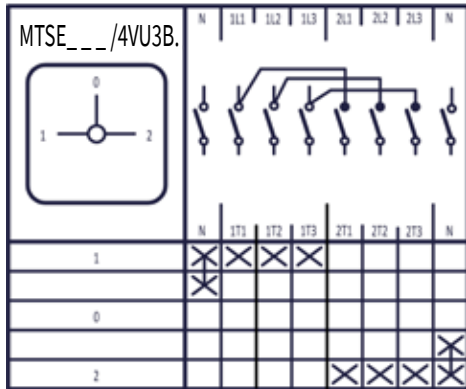

# DIMENSIONES (MM/INCH)

TIPO	Punte N	A1		A2		B		B1		B2		C		C1		C2		H	
		mm	pul.	mm	pul.	mm	pul.	mm	pul.	mm	pul.	mm	pul.	mm	pul.	mm	pul.	mm	pul.
MTSE-040 4VU3B	si	45	1,77	76	2,99	72	2,83	84	3,31	96	3,78	40	1,57	51,5	2,03	25,5	1,0	70	2,76
MTSE-040 4VU	no	45	1,77	76	2,99	72	2,83	84	3,31	96	3,78	40	1,57	51,5	2,03	25,5	1,0	70	2,76
MTSE-063 4VU3B	si	45	1,77	105	4,13	100	3,94	119	4,69	138	5,43	40	1,57	51,5	2,03	25,5	1,0	72	2,83
MTSE-063 4VU	no	45	1,77	105	4,13	100	3,94	119	4,69	138	5,43	40	1,57	51,5	2,03	25,5	1,0	72	2,83
MTSE-125 4VU3B	si	45	1,77	72	2,83	140	5,51	159	6,26	178	7,01	67	2,64	48	1,89	16	0,63	80	3,15
MTSE-125 4VU	no	45	1,77	72	2,83	140	5,51	159	6,26	178	7,01	67	2,64	48	1,89	16	0,63	80	3,15

pul. = pulgadas

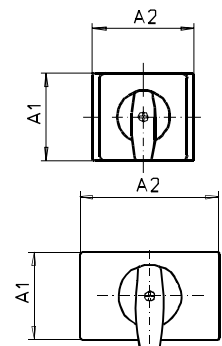
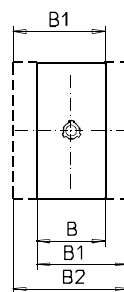
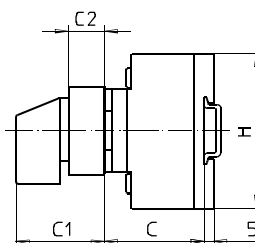
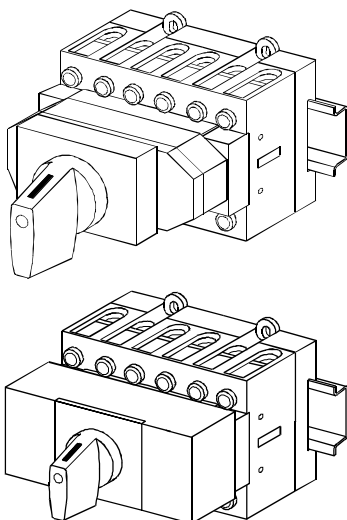

**MERZ Schaltgeräte GMBH + CO KG**

Kernerstraße 15  
D-74405 Gaildorf

Teléfono +49 (0) 7971 252-252  
Fax +49 (0) 7971 252-351

info@merz-schaltgeraete.de  
www.merz-schaltgeraete.de



*Switch to Quality!*